



FREE  
PATTERN  
OFFERED  
IN INDEPENDENT  
QUILT SHOPS TO  
COMPLEMENT THIS  
FABRIC COLLECTION.



**VROOOM!**  
**VROOOM!**

Featuring:  
Q1435 Little Hot Rod  
fabric collection by RL Studio



# VROOM! VROOM!



Please read all instructions carefully before starting. All instructions include a 1/4" seam allowance and strips are cut from selvage to selvage unless otherwise stated.

## Quilt Instructions:

Approximate size 69" x 93"

### 1. Cut the following:

**Fabric C** - cut 1 - 12 1/2" strip, subcut 3 - 12 1/2" squares

**Fabric D** - cut 1 - 6 7/8" strip, subcut 4 - 6 7/8" squares, cut 2 squares in half diagonally  and cut 2 squares in half diagonally 

cut 2 - 2" x 12 1/2"

cut 1 - 11 7/8" strip, subcut 4 - 11 7/8" x 6 7/8"

rectangles, cut rectangles in half diagonally according to the diagrams (directional fabric so use only triangles next to \*)



**Fabric F** - cut 3 - 12 1/2" strips, subcut 8 - 12 1/2" squares

**Fabric G** - cut 6 - 2 1/2" strips, sew strips end to end for one long strip, then subcut: 2 - 2 1/2" x 62 1/2" (SIDES) and 2 - 2 1/2" x 42 1/2" (TOP and BOTTOM)

**Fabric I** - cut 1 - 11 1/4" strip. Place 60° line of ruler over top raw edge, cut left side of triangle, next place 60° line of ruler over bottom raw edge lining up ruler with top edge of previously cut angle. Cut two 60° triangles.

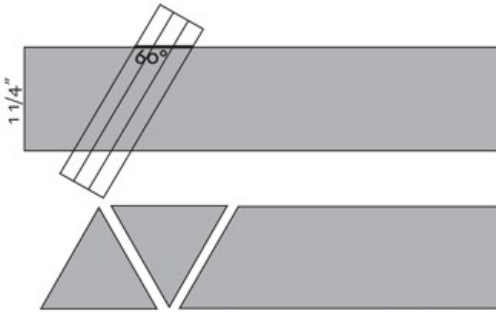

**Fabric J** - cut 19 - 2 1/2" strips (pair with O, N and L strips)

cut 6 - 2 1/2" strips, sew end to end for one long strip, then subcut: 2 - 2 1/2" x 68 1/2" (SIDES) and 2 - 2 1/2" x 48 1/2" (TOP and BOTTOM)

**Fabric K** - cut 2 - 9" x 9" squares

**Fabric L** - cut 5 - 2 1/2" strips

**Fabric M** - cut 5 - 2 1/2" strips, subcut 68 - 2 1/2" squares

**Fabric N** - cut 9 - 2 1/2" strips

cut 2 - 3 1/2" strips, subcut 12 - 3 1/2" squares

cut 11 - 1 1/2" strips, sew end to end for one long strip, then subcut 1st border - 2 - 1 1/2" x 60 1/2" (Sides) and 2 - 1 1/2" x 38 1/2" (Top and Bottom); 2nd Border - 2 - 1 1/2" x 66 1/2" (Sides) and 2 - 1 1/2" x 44 1/2" (Top and Bottom)

**Fabric O** - cut 5 - 2 1/2" strips

**Fabric P** - cut 5 - 2 1/2" strips, subcut 68 - 2 1/2" squares

**BINDING** - cut 9 - 2 1/4" strips, sew end to end and press in half.

### 2. Piecing Order:

1. Draw a diagonal line on the backside of 12 N 3 1/2" squares. Place one N square over each corner of 3 C 12 1/2" squares, right sides together. Stitch ON the diagonal line, trim 1/4" from seam. Press triangle outward.

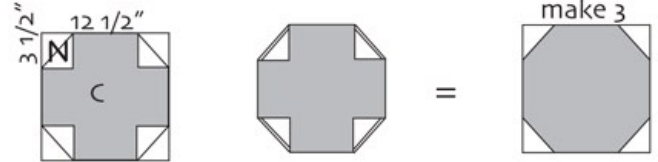

2. Sew D 6 7/8" triangles to all sides of 2 K 9" squares, opposite sides first. Pay attention to correct placement of directional triangles and center triangles evenly.

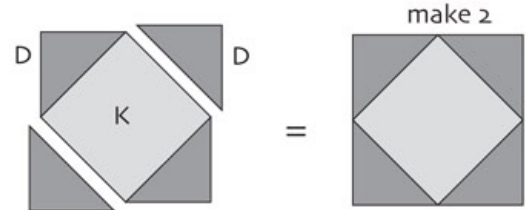

3. Sew D triangles to two sides of I 60 triangles. Pay attention to directional triangle placement. Next, sew D 2" x 12 1/2" strip to the top. Make 2 - 12" finished blocks (12 1/2" unf.)



4. Sew rows of blocks, then sew rows together according to the diagram.

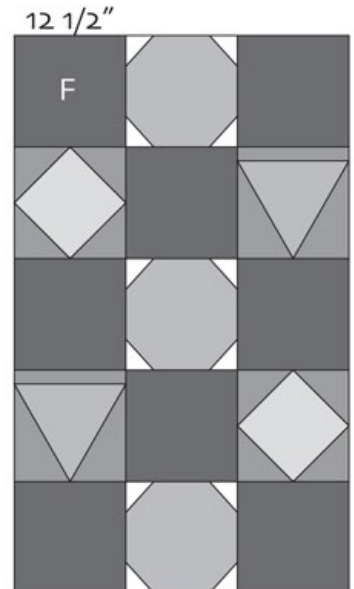

5. Sew individual **N**, **G**, **N** and **J** borders to the quilt, **SIDES** first, then **TOP** and **BOTTOM** borders according to the diagram. Press each border before sewing the next one.

6. Border Blocks: Make 18 - 8" finished (8 1/2" unf.) Block #1. Make 16 - 8" finished (8 1/2" unf.) Block #2.

First, sew **O** and **J** 2 1/2" strips side by side. Make 5 strip sets. Press ALL strips sets toward **Fabric J**. Subcut 34 - 4 1/2" segments. Make 9 strip sets by sewing **N** and **J** 2 1/2" strips, subcut 68 - 4 1/2" segments. Make 5 strip sets by sewing **L** and **J** 2 1/2" strips, subcut 34 - 4 1/2" segments.

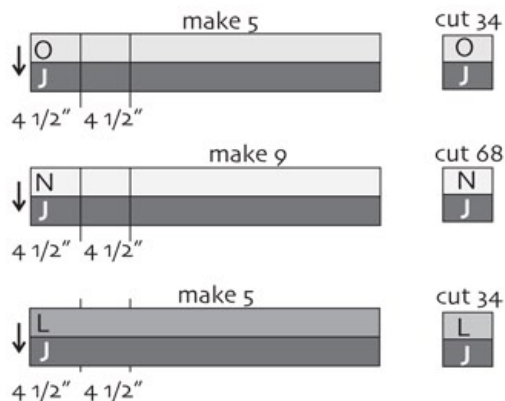

Next, draw a diagonal line on the backside of 68 **P** 2 1/2" squares. Draw a diagonal line on the backside of 68 **M** 2 1/2" squares.

Place **P** or **M** square over the strip set corner, right sides together, according to the diagram. Stitch ON the diagonal line. Trim 1/4" from seam. Arrows indicate pressing directions. Make the following border units:



Sew Blocks #1 and #2 by sewing units together by rows according to the diagram.



7. Sew blocks in order according to the diagram. See cover picture for blocks orientation. Sew **SIDE** borders to the quilt first, then sew **TOP** and **BOTTOM** borders according to the diagram on the next page.

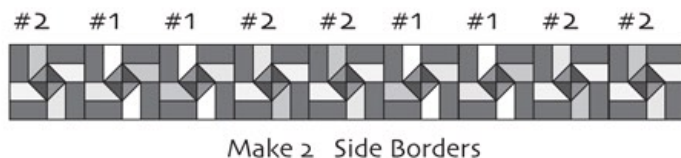
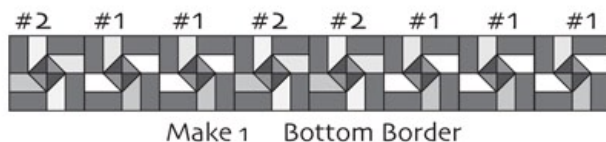
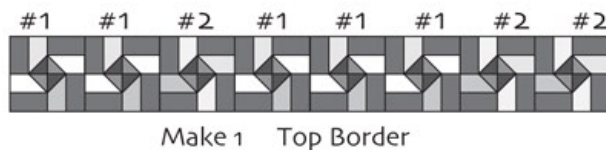

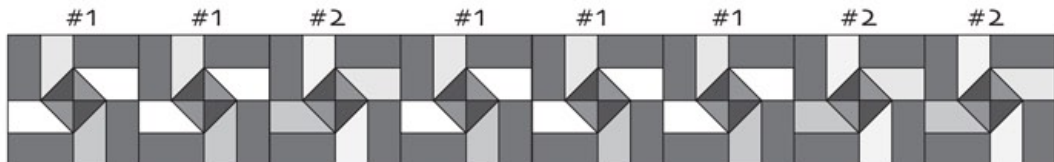

J 2 1/2" x 48 1/2"

N 1 1/2" x 44 1/2"

G 2 1/2" x 42 1/2"

N 1 1/2" x 38 1/2"

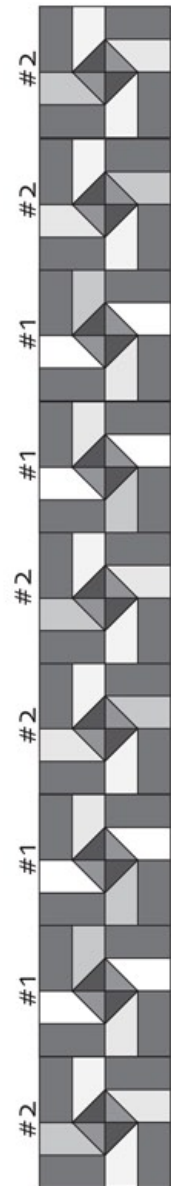

J 2 1/2" x 68 1/2"

N 1 1/2" x 66 1/2"

G 2 1/2" x 62 1/2"

N 1 1/2" x 60 1/2"

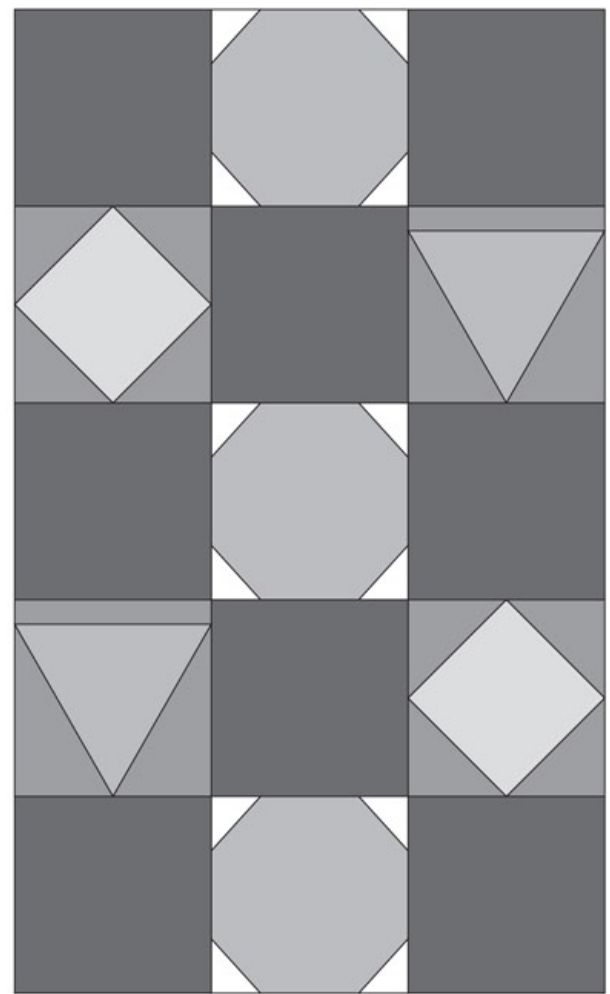

N 1 1/2" x 60 1/2"

G 2 1/2" x 62 1/2"

N 1 1/2" x 66 1/2"

J 2 1/2" x 68 1/2"

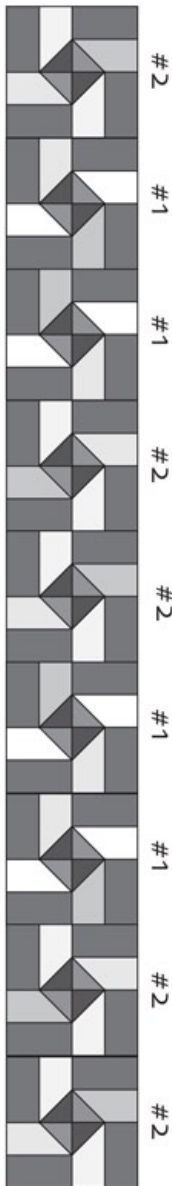

N 1 1/2" x 38 1/2"

G 2 1/2" x 42 1/2"

N 1 1/2" x 44 1/2"

J 2 1/2" x 48 1/2"

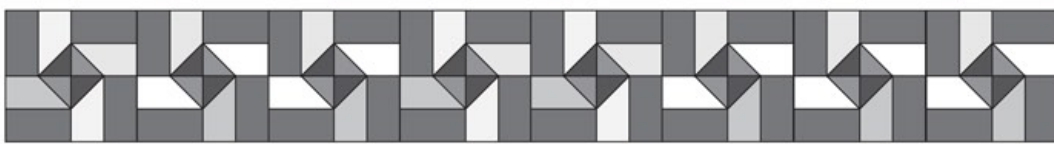

8. The quilt measures approximately 69" x 93". Make backing (**Fabric M**) at least 6" larger than the top. Baste together top, batting and backing. Quilt as desired. Attach binding (**Fabric P**) and enjoy!!

# Wall Hanging Instructions

## approximate size 49" x 48 1/2"

### Page 4

#### 1. Cut the following:

**Fabric A** - cut 2 - 9 1/2" x 30" and 2 - 9 1/2" x 30 1/2".  
Cut individual borders according to the diagram below.\*\*

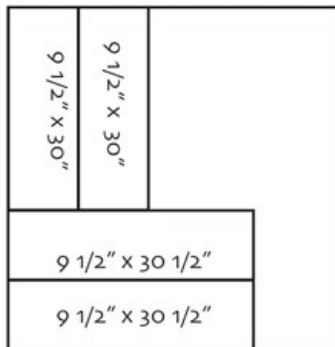

**Fabric B** - cut 1 - 28 1/2" x 28 1/2"

**Fabric C** - cut 2 - 9 1/2" x 9 1/2" squares

**Fabric D** - cut 1 - 9 1/8" strip, subcut 2 - 9 1/8" x 5 1/4" rectangles. Cut rectangles in half diagonally according to the diagrams. (Fabric is directional so use only triangles with \*)



cut 2 - 5 3/8" x 5 3/8" squares, cut in half diagonally



cut 1 - 1 3/4" x 9 1/2"

**Fabric I** - cut 1 - 8 5/8" strip, cut 1 60° triangle  
(see cutting directions on page 1)

cut 1 - 6 7/8" square

**Fabric P** - cut 2 - 1 1/2" strips, subcut 2 - 1 1/2" x 28 1/2" (SIDES) and cut 2 - 1 1/4" strips, subcut 2 - 1 1/4" x 30 1/2" (TOP and BOTTOM)

cut 1 - 3" strip, subcut 8 - 3" squares

**BINDING** - cut 6 - 2 1/4" strips, sew end to end and press in half

\*\*If **A** border measurements are slightly different, cut center square **B** with **P** borders to measure length of your fabric **A** pieces.

#### 2. Piecing Order:

1. Draw a diagonal line on the backside of 8 **P** 3" squares. Place one square over each corner of 2 **C** 9 1/2" squares, right sides together. Stitch ON the diagonal line, trim 1/4" from seam. Press triangles outward.

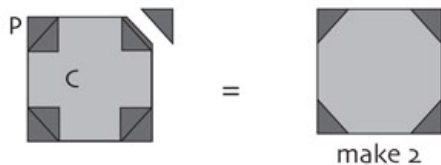

2. Sew **D** triangles around one **I** 6 7/8" square, opposite sides first. Center triangles evenly.

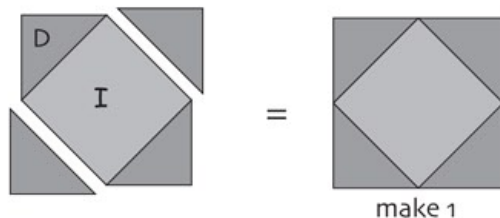

3. Sew **D** triangles to two sides of one **I** 60° triangle. Next, sew **D** 1 3/4" x 9 1/2" strip to the top of the block.

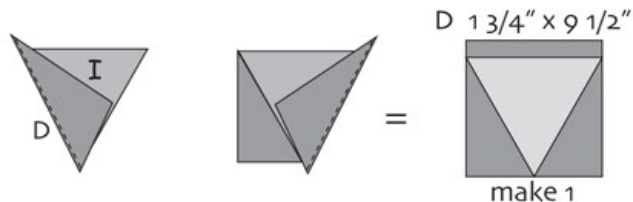

4. Sew **P** borders around center square **B**, SIDES first, then TOP and BOTTOM borders.

5. Sew blocks from step 1, 2, and 3 to both ends of **A** TOP and BOTTOM borders according to the diagram below.

6. Sew **A** borders to the quilt, SIDES first, then TOP and BOTTOM borders.

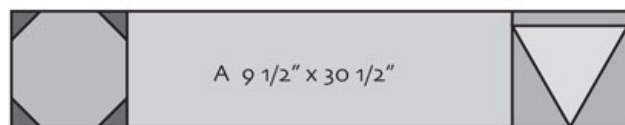
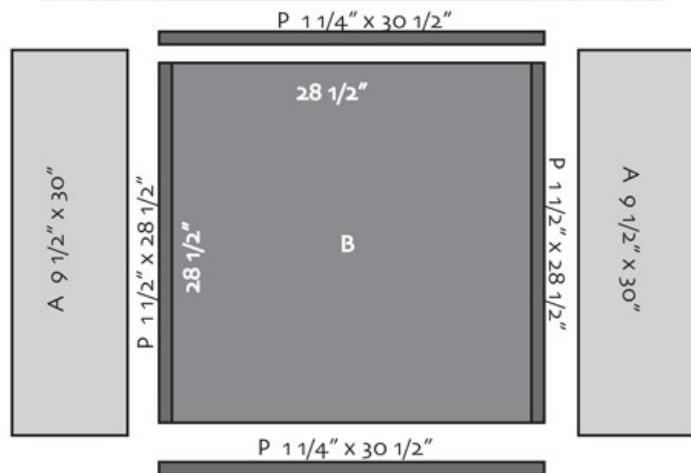
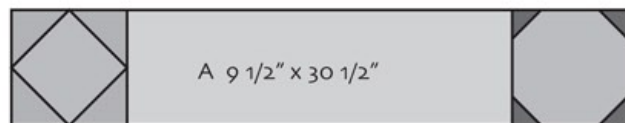

7. The quilt measures approximately 49" x 48 1/2". Make backing (**Fabric P**) at least 6" larger than top. Baste together top, batting and backing. Quilt as desired. Attach binding (**Fabric P**) and enjoy!!

# Pillow Instructions

approximate size 25 1/2" x 31 1/2"

Page 5

## 1. Cut the following:

**Fabric A** - cut 1 - 9 1/2" x 20"

**Fabric E** - cut 2 - 3" x 11 1/2" (SIDES)

cut 2 - 5 1/4" x 27" (TOP and BOTTOM)

**Fabric H** - cut 2 - 1 1/2" strips, subcut 2 - 1 1/2" x 9 1/2" (SIDES) and 2 - 1 1/2" x 22" (TOP and BOTTOM)

**Fabric K** - cut 4 - 3" strips, subcut 2 - 3" x 21" (Sides) and 2 - 3" x 32" (TOP and BOTTOM)

**Fabric O** - Backing - cut 2 - 18" x 32"

## 2. Piecing Order:

1. Sew individual **H**, **E**, **K** borders around center block **A**, SIDES first, then TOP and BOTTOM borders, according to the diagram.

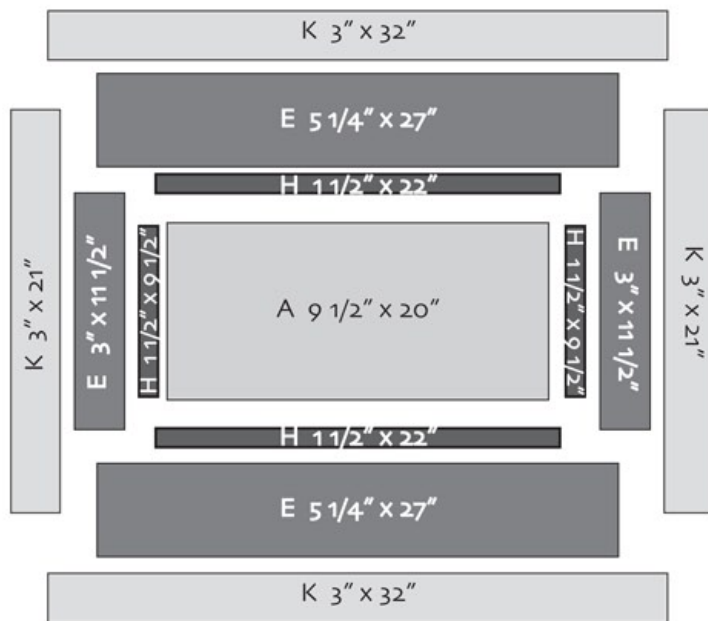

2. Double fold then topstitch one long side of both backing pieces.

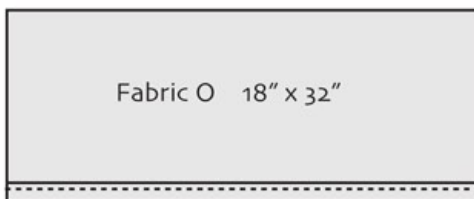

make 2

3. Layer batting, pillow top right side up, backing pieces right sides down. Match raw edges and pin together. Overlap backing pieces for opening. Stitch 1/4" around edge of pillow. Clip corners and turn pillow inside out.

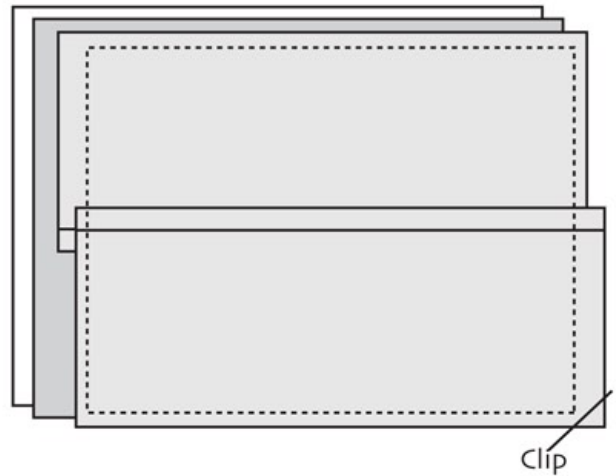

4. Stitch in the ditch between **E** and **K** borders to create a flange. Insert standard pillow and enjoy!!

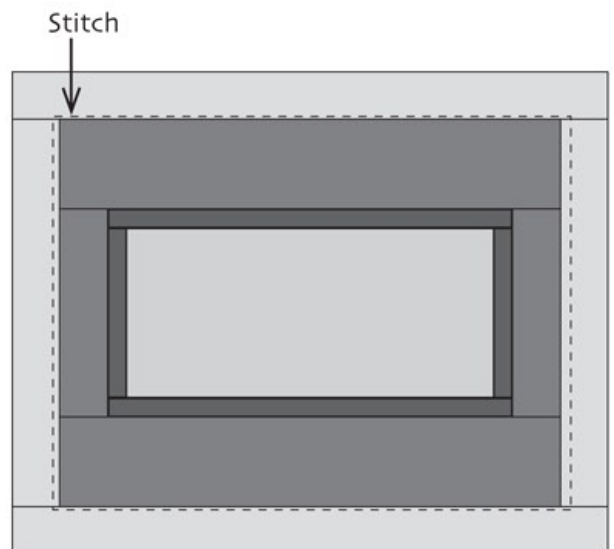

# VROOM! VROOM!

Q1435

From **Little Hot Rod**, a fabric collection by **RL Studio**



**Fabric A**  
83701-495  
WH: 5 Rows of Blocks (60")  
P: 1 Row of Blocks (10")



**Fabric B**  
83702-793  
WH: 1 yard



**Fabric C**  
83703-359  
Q: 1/2 yard  
WH: 3/8 yard

**Fabric D**  
83703-459  
Q: 7/8 yard  
WH: 5/8 yard



**Fabric E**  
83704-345  
P: 5/8 yard

**Fabric F**  
83704-945  
Q: 1 1/3 yards



**Fabric G**  
83705-199  
Q: 1/2 yard



**Fabric H**  
83706-199  
P: 1/4 yard

**Fabric I**  
83706-599  
Q: 1/2 yard  
WH: 3/8 yard



**Fabric J**  
83707-493  
Q: 2 1/8 yards



**Fabric K**  
83708-793  
Q: 1/3 yard  
P: 1/2 yard

**Complements:**  
Q1875



**Fabric L**  
31072-333  
Q: 1/2 yard



**Fabric M**  
31072-444  
Q: 1/2 yard  
(5 3/4 yards for backing only)

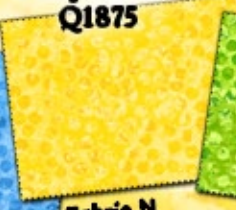

**Fabric N**  
31072-555  
Q: 1 3/8 yards

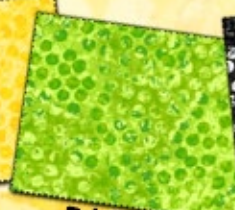

**Fabric O**  
31072-757  
Q: 1/2 yard  
P: 1 1/8 yards  
(backing only)



**Fabric P**  
31072-991  
Q: 1 1/4 yards (includes binding)  
WH: 3/4 yard (includes binding)  
P: 3 1/3 yards for backing only



**Quilt** Approx. 69" x 93"



**Wall Hanging** Approx. 49" square



**Pillow** Approx. 31.5" x 25.5"

